

**PLEASE READ THESE INSTRUCTIONS CAREFULLY BEFORE INSTALLATION**

**IMPORTANT INSTALLATION INFORMATION**

1. Normal operating environment and temperature: -40°C-+50°C. Fixture is suitable for Airport, Car Dealerships, Achitectural, Factory, Warehouse, High Mast lighting and stadium lighting.
2. Before commencing installation or maintenance, ensure electricity is switched off at the mains. Installation or maintenance should be carried out by a qualified electrician.
3. Mounting height range of 3 to 12 meters, this model is suitable for outdoor lighting.
4. The light fixture luminous surface must not be installed facing upwards in outdoor installation.
5. The lenses or luminous surface of the light fixture should be cleaned regularly, to prevent dust or similar debris from covering it.
6. Light fixture should not be installed nearby or on flammable materials and must be installed away from heat sources, at least 100cm distance.
7. All light fixtures run hot therefore the space surrounding the light fixture shall have adequate airflow spacing of at least 100cm omni-directionally from the outer case. Fire hazards and local safety ordinances shall be taken into consideration by the installer before commissioning.

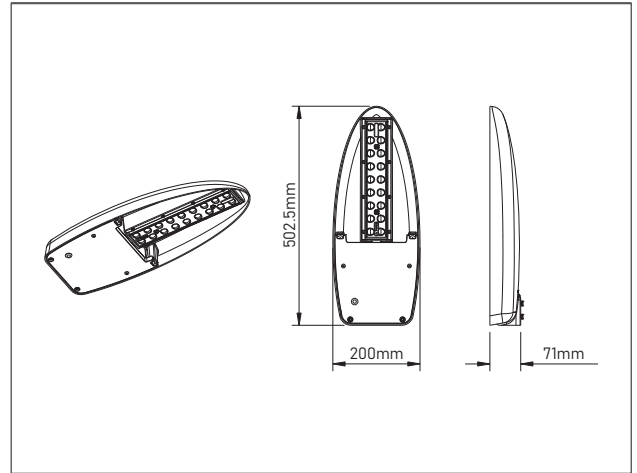

**LEAVE A COPY FOR THE USER / MAINTENANCE ENGINEER FOR FUTURE REFERENCE**

**Installation Instruction**

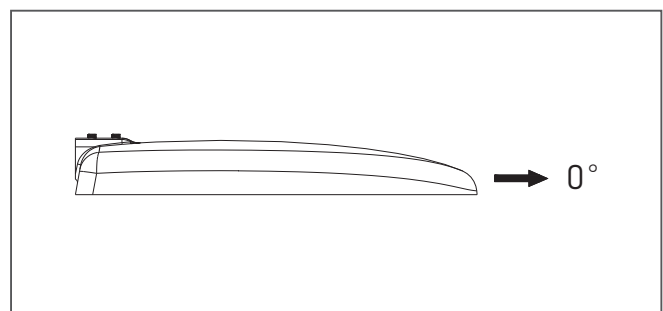
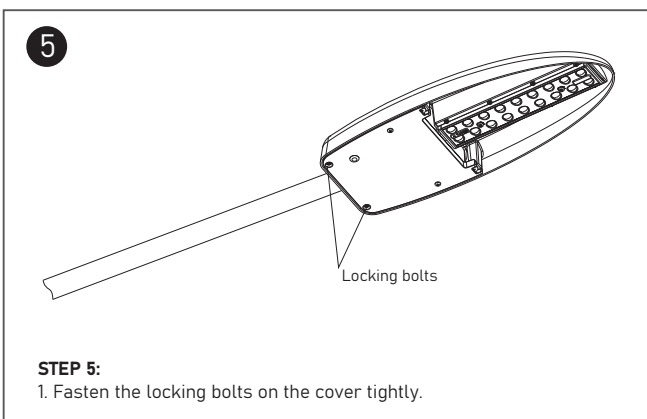
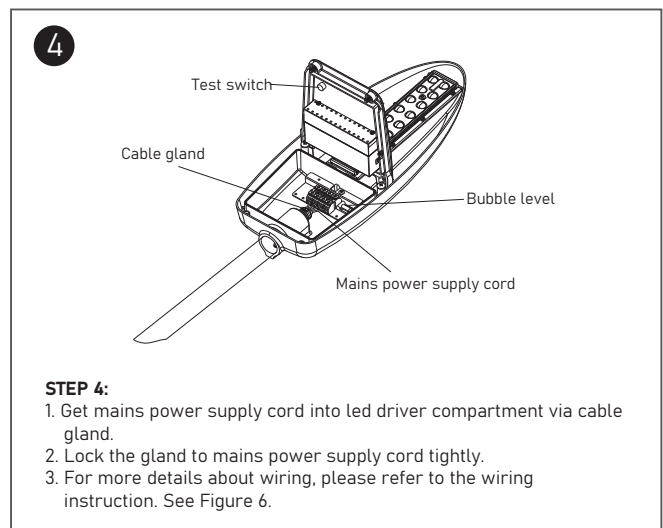
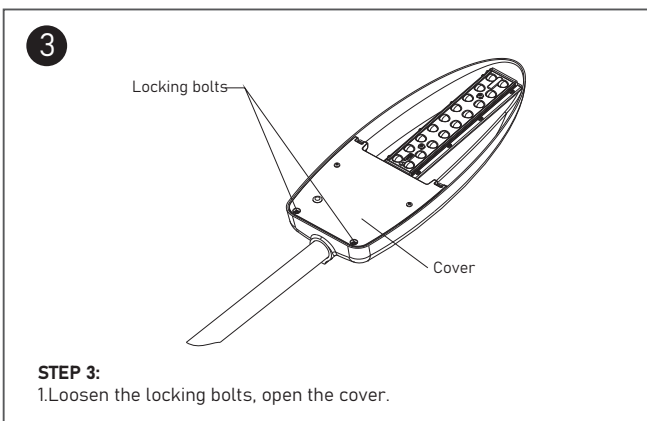
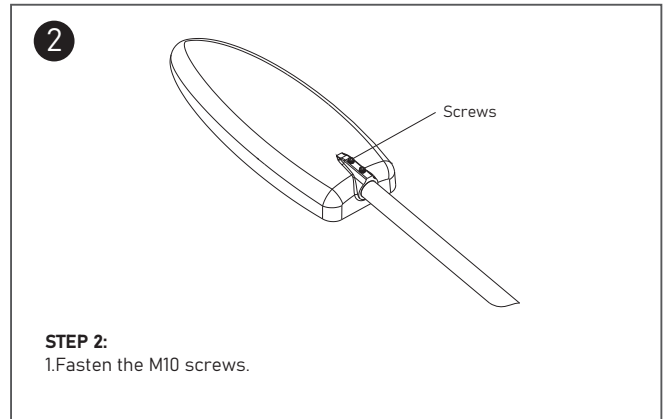
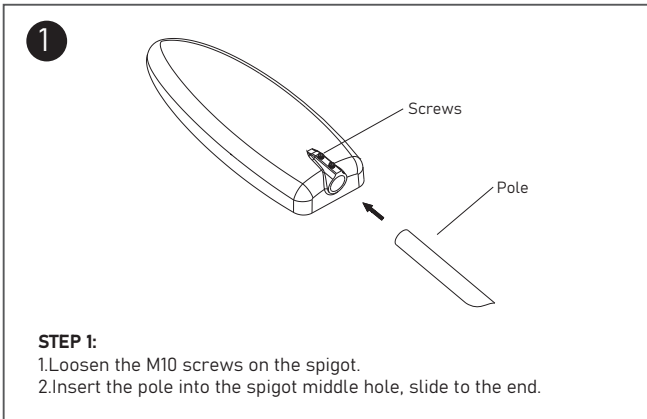

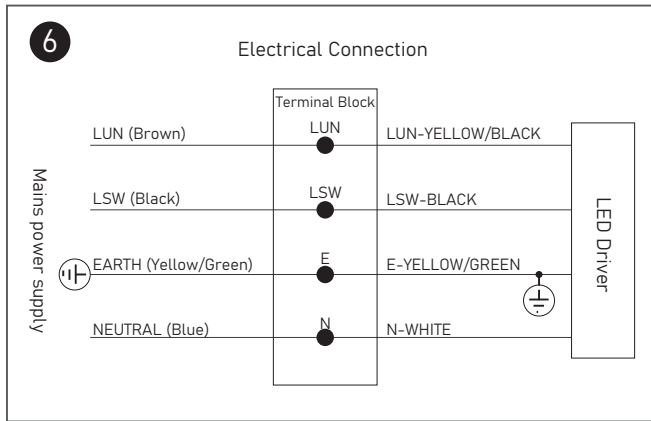

**Main specifications**

Model No.	System Wattage	Dimensions (L x W x H)	Weight	EPA*	Ambient Temperature	Ingress Protection
SL040MAKO-EM	40W	502.5mm (19.78") x 200mm (7.87") x 71mm (2.80")	5.88kg (12.9lbs)	0.076m <sup>2</sup>	0°C to +48°C	IP66
Input Voltage: 220 to 240V~ 50/60Hz						

**Common causes and solution**

Encountered Problem	Possible Cause	Remedy
Module does not light up	Internal wire disconnected	Open the light fixture and locate the loose wires, reconnect the connectors or wires. And retest.
	LED driver failure	Open the light fixture and check for disconnected wiring. If all wires are fine, then replace the LED driver with a new one and retest.
	Module failure	If all the above remedies are trialed and still not working, then the light module is most likely failed. Contact us for replacement and warranty information.



This logo indicates that this product must not be disposed with other wastes. Please recycle light fixture to prevent environmental hazard and threats to human health resulting from improper disposal.

Rev. Date: V7 01/01/2026