

# INSTALLATION GUIDE

## CORSO SOLAR ENGINES

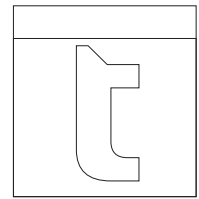

**SSCORSO55**  
55W SOLAR PANEL  
380Wh BATTERY



**SSCORSO110**  
110W SOLAR PANEL  
1100Wh BATTERY



**SSCORSO175**  
175W SOLAR PANEL  
1690Wh BATTERY

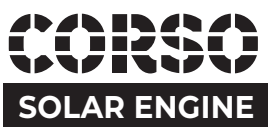

SCAN  
HERE



Scan QR code for a  
video installation guide  
for Corso Solar Engines.

---

## 1 PRODUCT OVERVIEW

The Corso Solar Engine is a high-performance, self-contained solar lighting system designed for reliable outdoor illumination without the need for grid power.

It is suitable for applications including:

- Pathways and shared spaces
- Car parks and public areas
- Roadways and access roads
- Remote or off-grid locations

The Corso Solar Engine integrates:

- Solar panel
- Battery (LiFePO<sub>4</sub>)
- Controller
- 2 X Power Outputs
  - One LED output from solar controller
  - A direct battery output for specific applications.

Most components are pre-assembled to simplify installation.

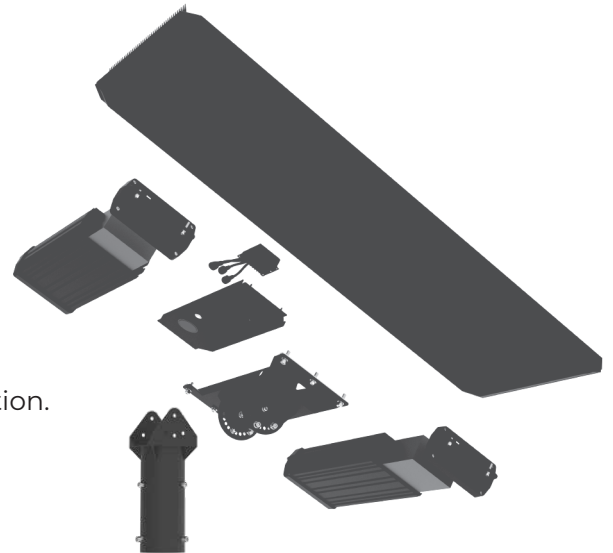

## 2 SAFETY & HANDLING

**Before installation, read this manual in full.**

General Safety

- Installation should be carried out by a qualified installer
- Follow all relevant local safety requirements for working at heights
- Ensure pole and mounting structure are certified and stable.

Handling

- Handle all components with care
- Do not drop or apply excessive force to the unit
- Do not place heavy objects on the solar panel.

Environmental Considerations

- Do not install in shaded locations
- Avoid areas prone to flooding or full water immersion.

## 3 SYSTEM COMPONENTS

The Corso Solar Engine consists of:

- Solar Panel – Converts sunlight into electrical energy
- Panel Support Bracket – Secures and angles the panel
- Battery & Controller Housing – Contains LiFePO<sub>4</sub> battery and control system
- Spigot Mount – Connects system to pole

Additional components may have been supplied also, including:

- LED Luminaire – Such as a Mako Area Light
- Clamp style bracket to suit Mako.

## 4 FIXINGS & TOOLS SUPPLIED

- Standard screws
- Anti-theft screws
- Allen key
- Anti-theft key.

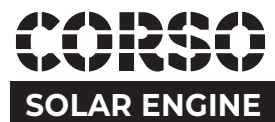

---

## 4 PRE-INSTALLATION REQUIREMENTS

### 4.1 Site Selection

- Install in a location with full sun exposure throughout the day
- Avoid shading from trees, buildings, or other structures.

### 4.2 Panel Orientation (Critical)

- In Australia: Panel must face North
- Ensure correct tilt angle based on location
  - 30 degree tilt recommended for majority of Australian Installations
  - 45 degree tilt recommended for Tasmania
  - 15 degree Tilt for Far Northern Australia, ie Townsville and above - locations such as Darwin, Pilbara, Katherine, Cairns etc.

### 4.3 Temperature Limits

- Operating range: -20°C to 70°C
- Charging range: 0°C to 70°C

The system includes temperature protection and may stop charging outside these limits.

### 4.4 Pole Requirements

- Confirm pole diameter matches spigot.
- The standard spigot entry is 98mm. A smaller 85mm spigot entry bracket is available as a separate item. Tigerlight product code SSCORSO-76BKT
- Ensure pole is structurally sound and installed correctly.

---

## 5 INSTALLATION PROCESS

# STEP 1

### 5.1 Assemble LED Clamp Bracket if purchased

- Feed the luminaire's LED cable through the bracket's spigot.
- Attach affix the LED luminaire to the arm by tightening the grub screws.

There is an internal bubble level in most Tigerlight lights to ensure light is level.

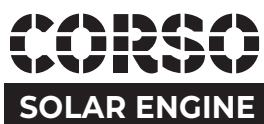
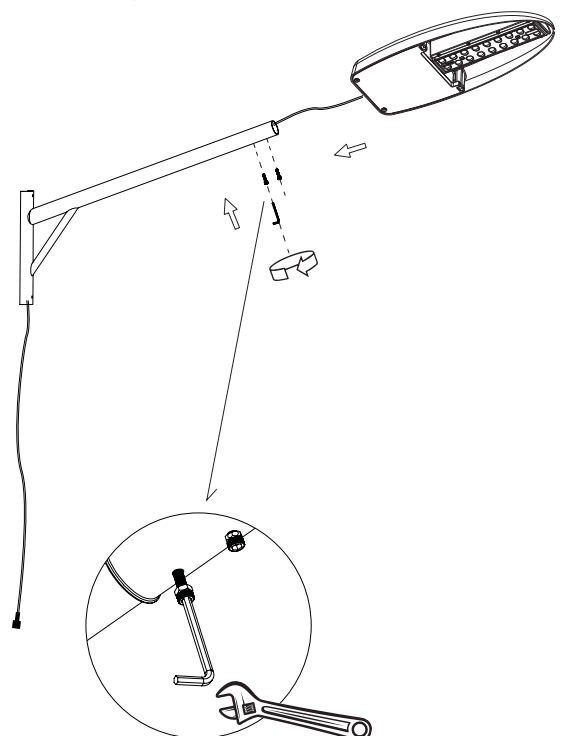

## 5 INSTALLATION PROCESS (CONTINUED)

### STEP 2

#### 5.2 Mount LED Arm to Pole

- Position LED arm onto pole
- Tighten securely
- Ensure cable exits through top of pole.

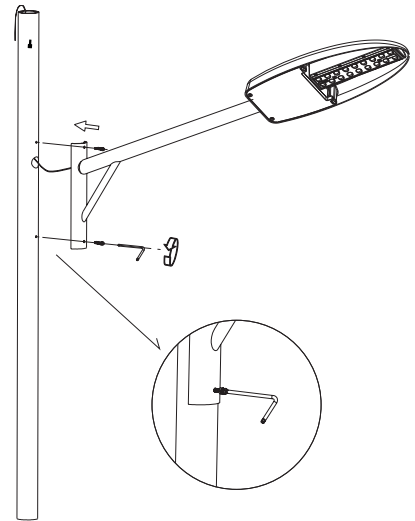

### STEP 3

#### 5.3 Prepare Solar Panel Assembly

- Remove pre-installed screws from solar panel support.

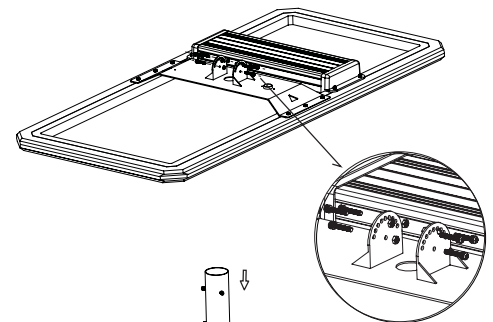

### STEP 4

#### 5.4 Attach Spigot to Solar Panel

##### 5.4.1 Position spigot

- Position spigot onto panel support
- Lightly fasten using central screw.

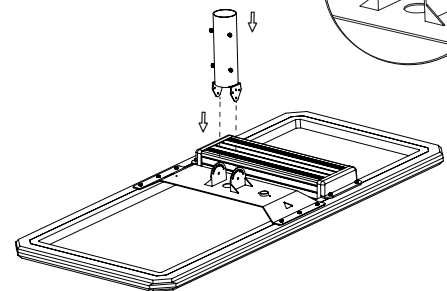

##### 5.4.2 Tilt spigot and orientate panel

- Select desired tilt angle (0°, 15°, 30°, 45°).
- Refer section 4.2 for best tilt angles
- Orientate the panel due North in Australia.

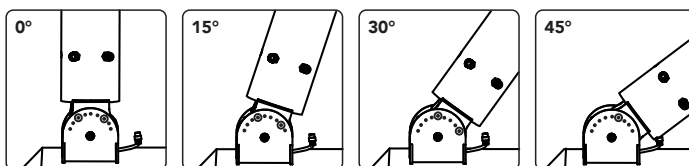

Holes 3&7

Holes 2&6

Holes 1&5

Hole 4

**Important: Correct tilt and orientation are critical for system performance. If unsure, please reach out to Tigerlight. Refer back page for contacts.**

##### 5.4.3 Secure Corso Solar Engine

- Secure using screws removed earlier
- Fully tighten all fixings.

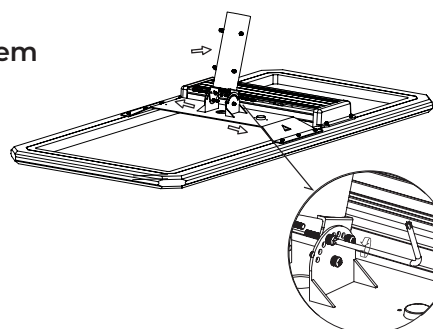
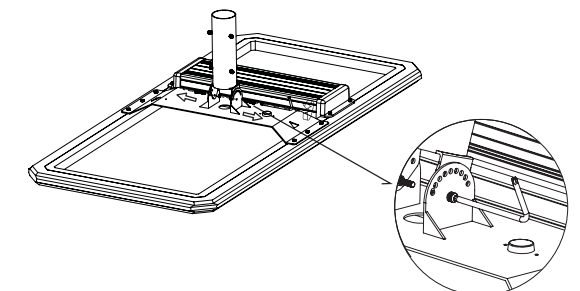

## 5 INSTALLATION PROCESS (CONTINUED)

### STEP 5

#### 5.5 Mount Solar Assembly to Pole

- Position solar assembly onto pole.
- Feed LED cable through spigot opening.

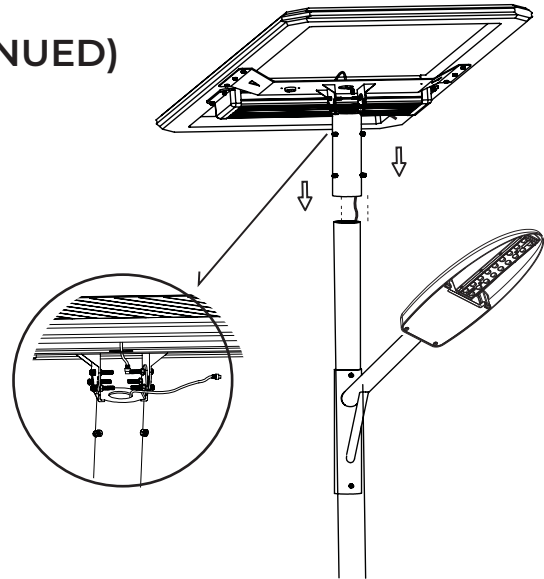

### STEP 6

#### 5.6 Secure Solar Assembly

- Tighten spigot firmly to pole
- Ensure no movement or looseness.

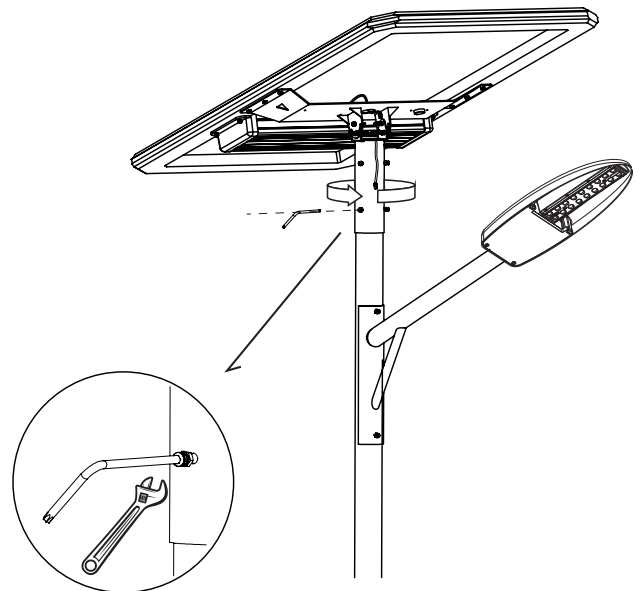

### STEP 7

#### 5.7 Electrical Connection & Power-On

- Connect waterproof connectors labelled “LED”. (Note the connector labelled BATT - this is the direct battery connection and will not power standard light fittings. The plug on this is will not connect to the LED plug either.)
- Ensure connection is fully sealed
- Press the stainless steel ON button next to the Microwave sensor to activate system
- A red light will be visible in the microwave sensor showing the engine is on and charged.

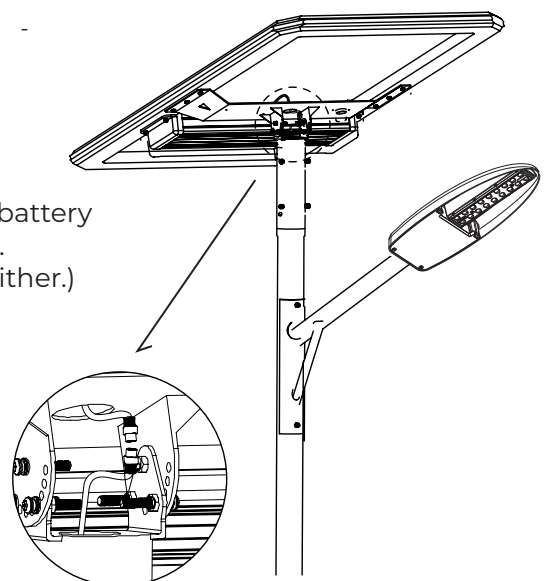

**INSTALLATION COMPLETE**

## 6. COMMISSIONING

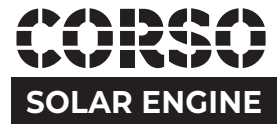

Once installed, system will operate automatically:

- Turns ON at night
- Turns OFF at sunrise

Check for:

- Indicator light on sensor (steady or flashing)

Indicator Light	State of Indicator Light	Description of Indicator Light	State of Remote Controller System
Red	Normally on	Normal system	Idle/discharge
	Slow flash	Charging	Charge
	Fast flash	System failure	Short circuit/open circuit /over-discharge/PV over-temperature/ BV over-temperature/EBMS/over-temperature

- Light activation in low-light conditions or after covering solar panel for 15-20 seconds simulating darkness.

## 7. TROUBLESHOOTING

Light not turning on

- Check system is switched ON
- Confirm connectors are fully engaged
- Ensure panel has received sufficient sunlight

Short runtime

- Check for shading on panel
- Confirm correct panel orientation
- Consider recent weather conditions (cloud/rain)

No charging

- Check panel is clean and unobstructed
- Confirm installation direction (North-facing in Australia).

## 8. MAINTENANCE

To ensure long-term performance:

- Clean solar panel periodically (no harsh chemicals)
- Inspect fittings and tighten if required
- Check for debris or shading over time

Battery Maintenance

- If stored, recharge every 4 months to maintain health of battery.

**tigerlight**<sup>®</sup>  
tigerlight.com.au

T 1300 184 437  
F 02 9913 8876  
E info@tigerlight.com.au

**National Support & Distribution Centre**  
Unit 8, 1 Vuko Place,  
Warriewood, NSW 2102

**Western Australia Office & Warehouse**  
Unit 3, 1 Distinction Road,  
Wangara, WA 6065