



HACCP CERTIFIED
FOOD SAFE

tigerlight®

HIGH-PERFORMANCE
INDUSTRIAL LIGHTING



HACCP FOOD SAFETY ACCREDITATION

LIGHTING INSTALLED ON FOOD PREMISES

The light fittings below have been certified by HACCP International as being suitable for use in food production, processing and food handling areas, under the SSZ (Splash or Spill Zone) category.

The accreditation is based on Australian Standard AS4674 Design, construction and fit-out of food premises. Suitability of the product is evaluated on a fitting's design and construction, composition, impact-resistance and, importantly, the cleanability of the light fitting.



Tiger IP69K Batten - Food Grade

Product code: PEFG1200NW

HACCP CERTIFIED FOOD SAFE

36W

5700 lm

1200mm Batten

600mm 20W also available

Quality tubular batten, designed to resist ingress of high pressure & high temperature water, steam and detergents in cleaning and sanitising procedures; dust and corrosive gases. PMMA/acrylic for durability & thermal properties. No glass. Stainless steel (316 grade) end caps & brackets. Fully sealed against air and water intake. Rated IK09 for robust physical environments.



The installation must follow regulations in regards to the distance the light is placed from the ceiling. HACCP International recommend a 100mm distance between the bracket and the horizontal surface. This is important for cleanability of the light.

Tiger IP69K Batten - Food Grade Integrated Maintained Emergency



Product code: PEFG1200NW-EM

HACCP CERTIFIED FOOD SAFE

36W

5400 lm

1200mm Batten

4W 730 lm Emergency output

Built-in battery module provides valuable emergency capability
36W 1200mm 150 lm/W 5400 lm
4W emergency output
730 lm output in emergency mode
3 hour emergency run-time
4 core cable.

Emergency Classification

CO-C180	D160
C90-C270	D50



Emergency battery test button with indicator light on end of fitting



The installation must follow regulations in regards to the distance the light is placed from the ceiling. HACCP International recommend a 100mm distance between the bracket and the horizontal surface. This is important for cleanability of the light.



Primo 15K Canopy Light

Product code: CP15K100PM

HACCP CERTIFIED FOOD SAFE

100W 15,000 lm DIMMABLE 1-10VDC

Canopy light for low ceilings & clean rooms.
Outstanding 150 lumens/watt performance.
Wide 115 degree beam spread.
Dimmable to 10% output with motion sensors.
Heavy duty PMMA acrylic lens for food safety - no glass.
Simple flush-mounted installation.
Rated IP65.

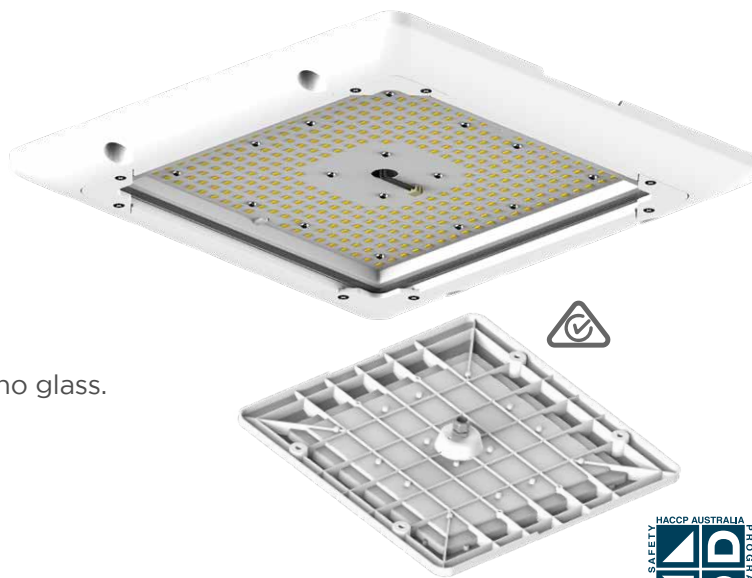

DESIGNED AND BUILT IN KOREA
FOR EXTRA HEAVY DUTY



Primo 23K Canopy Light

Product code: CP23K145PM

HACCP CERTIFIED FOOD SAFE

145W 23,000 lm DIMMABLE 1-10VDC

Canopy light for higher ceilings & lux levels
Outstanding 160 lumens/watt performance
Dimmable to 10% output with motion sensors
Simple flush-mounted installation
HACCP Certified Food Safe (Splash & Spill Zone)
Heavy duty PMMA acrylic lens for food safety - no glass.
Rated IP65.

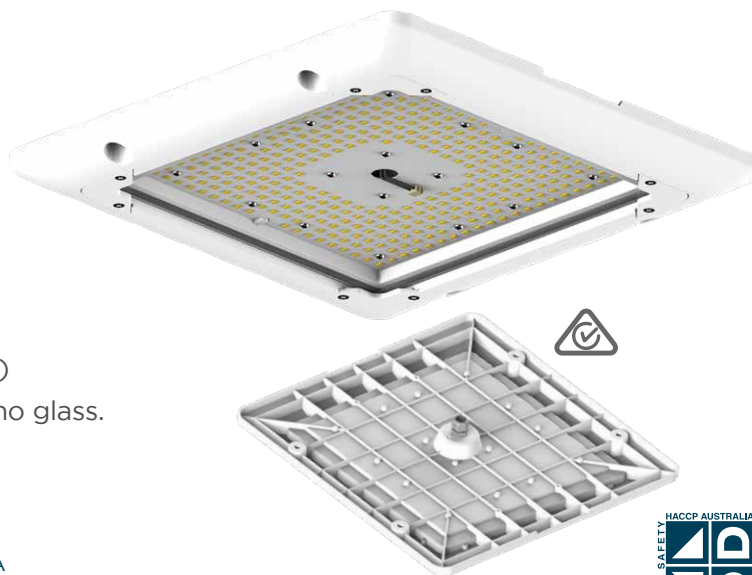

DESIGNED AND BUILT IN KOREA
FOR EXTRA HEAVY DUTY

